

# PumpLines

Innovation... Technology... Leadership

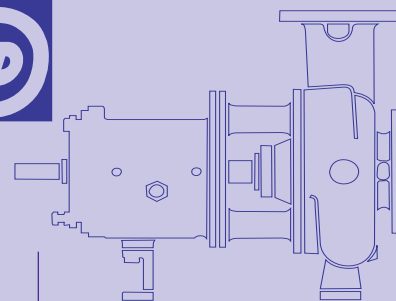

## PRO Services® Onsite Maintenance Management Makes a Difference at Cytec

Cytec Industries is one of the world's leading specialty chemicals and materials companies. They are a major competitor in all their principal specialty product lines and are frequently the technology leader in the markets they serve. Their diverse portfolio of products is supported by vertical integration, which distinguishes them from most other specialty chemical companies. They produce the major building block chemicals used in the manufacture of many of their specialty chemicals.

Cytec's Building Block Chemicals business is a major producer of chemical raw materials and intermediates. One of their world scale operations is in Louisiana (Fortier) where they manufacture high quality products and ship around the globe. Acrylonitrile, Acrylamide monomer, Melamine, Methyl Methacrylate (MMA), and Sulfuric Acid/Oleum. MMA and Melamine are manufactured at the Fortier site through associated joint ventures (CYRO Industries and American Melamine Industries).

All of these are important ingredients in every day life, but all, in their base state, are very aggressive liquids. Handling these chemicals safely and efficiently are the primary concerns of the Cytec manufacturing team.

As with most North American-based manufacturing, profitability is important to remain globally competitive. Suppliers such as Cytec have had to be extremely creative in enhancing profitability. The Cytec – Fortier management turned to ITT PRO Services.

### Assessing the Opportunities

PRO Services completed a plant assessment, concentrating on the enormous pump populations. Pumps represented the greatest opportunity to improve the operational bottom line.

"The main goal of the pump initiative was to reduce the costs associated with the centrifugal pumps used at Fortier, by reducing operating and maintenance cost as well as increase their Mean Time

*continued on page 8*



Dan Pereira, ITT PRO Services Engineer (left) discusses maintenance cost reduction with Cytec Reliability Principal Engineer Dennis McIntyre and Bob Applewhite, Mechanical Engineer.

### IN THIS ISSUE:

#### Feature:

*PRO Services® Onsite Maintenance Management Makes a Difference at Cytec* .....Page 1

*Flood Control Staying Above Water Below Sea Level!* .....Page 2

*Goulds Improved "Q" Impeller Hydraulics for Model 3620* ....Page 3

#### Material Matters:

*Practical Failure Avoidance and Prevention (Analysis of a Heat Stress Damaged Slurry Pump)*.....Page 4

#### New Products:

*New Goulds Shearpeller™ Stops Pump Plugging* .....Page 5

*Line Extension for the ChemBasePLUS™* .....Page 5

*Websites Get a Face-Lift* .....Page 6

*Goulds Pumps Receives Chemical Processing Magazine Award*.....Page 6

#### Personnel Moves

*New Assignments for Taylor, Tuttle and Manna*.....Page 7

*John Crane and Goulds Pumps Celebrate 50,000 Milestone of the Type EZ-1 Seal* .....Page 7

*Goulds and Flygt Recieve Order From California DWR For \$6.7M*....Page 8

View this issue and previous issues of **PumpLines** on our website at [www.gouldspumps.com](http://www.gouldspumps.com)

© Copyright 2005 Goulds Pumps, Inc., a subsidiary of ITT Industries, Inc.

Goulds Pumps



ITT Industries  
Engineered for life

## Goulds and Flygt Recieve Order From California DWR For \$6.7M

### Dick McAdam

Vice President – Sales  
ITT Engineered Products Division

**The Power of One**, our ITT theme, was demonstrated by Goulds and Flygt recently in the water and wastewater market. The number one process pump and the number one submersible pump manufacturer combined to win a very large order. For Goulds, the order consists of five (5) model VIT-UG 36 EHC, five stage vertical turbine pumps in 316SS construction, driven by 4000 HP synchronous motors with excitation systems. The pumps will be manufactured at the Goulds Pumps Vertical Products Operation (VPO) in City of Industry, California. This significant win is the culmination of many factors including the proper product, competitive price, and, most

importantly, a new partnership this year between IPG and Flygt in Northern California and the Pacific Northwest.

The South Bay Aqueduct in Byron, California is one of several existing conduits for the transport of water from the Delta to the Bay Area and contributes to the potable water supply of over two million people. As a result of insufficient pumping capacity and lack of backup pump units during emergencies and maintenance, the State of California Department of Water Resources (DWR) proposed improvements to and expansion of the existing facilities in September of 2003. Completion of this project will bring the existing capacity of the system up to its design capacity, and provide for greater reliability and flexibility.

In early 2004, the State issued a particularly onerous set of prequalification documents which could not be met by most North American pump manufacturers. However, the combined efforts of Goulds and Flygt allowed ITT to be approved



as an acceptable vendor. Acting together, Goulds and Flygt provided the customer care and specification compliance. Technical and commercial resources were available at Goulds Vertical Pump Operation. We cooperated closely to prepare a proposal in 100% compliance with the intensive specifications for materials, welding, design, and testing. Ultimately, the unified efforts paid off. On bid day, ITT's total evaluated price (which considered the overall efficiency of the proposed pump assemblies) was superior to that of the five other vendors.

**The Power of One.**

## Pro Services Onsite...

*continued from page 1*

Between Failure" said Dan Pereira, the on-site PRO Services Engineer.

Six Sigma tools were used to define the program. Recommended actions were specific and accountable. Initiatives were implemented plant wide starting in 2000.

### Intelligent Flow Control

A prime example of pump modifications that will produce operational savings is the Acrylo Plant MET Injection Pumps. These pumps have long been a maintenance nightmare. Operating in series, due to electrical restrictions, the units have high maintenance occurrences and high energy usage. The solution was to utilize three separate pump controllers, one on each pump. PumpSmart® controls the pumps' output based on the system demand. They will control speed and output as dictated by the MET System. Horsepower requirements remain below 200 eliminating the need for costly pump and driver upgrades. Pumps will now run at Best Efficiency Point (BEP) and avoid maintenance required due to cavitation, dry running, and seal failure. The energy savings alone will exceed \$50,000 US annually. Add to that maintenance avoidance of another \$50,000 and you have a total annual savings of over \$100,000.

### Lowering Maintenance Costs

Another example of cost reduction took place in the Melamine plant where two horizontal splitcase pumps were experiencing premature mechanical seal failure to the tune of \$24,000 annually. Initially, a switch was made from cartridge seal to split seal. The failures did not drop significantly. After some additional troubleshooting, the PRO Service engineer and Cytec maintenance personnel found the real problem; a simple, undersized sleeve nut. After consulting with the seal vendor, the properly sized sleeve nut and a split cartridge seal were used. The ease of working on these units increased and so did the reliability of the pumps. The average annual maintenance cost per pump has dropped to \$4,000.

Four large Weir/ASH rubber lined slurry pumps, equipped with dynamic seals were presenting problems. Not only were the annual maintenance costs high (\$97,200 total or \$24,300 each) but they were also difficult to repair due to their size. In working with plant production and maintenance personnel, PRO Services determined that the pumps were failing because the pumpage was permeating the liners, swelling the parts and causing them to fail. The pumps were fitted with a flush gland. Water was introduced to dilute and cool the liquid which reduced the effect on the rubber liners. 2004 maintenance costs on all four pumps are \$0...that's zero.

### Results are Measurable

Dennis McIntyre, P.E., Principal Engineer Equipment Reliability, stated, "There are many day-to-day cost reduction activities that are directly attributable to our partnership with ITT PRO Services."

Measurable costs include MTBF increase, replacement parts inventory reduction, maintenance cost savings and energy usage decrease. The immeasurable benefits include, training to refresh personnel general knowledge of pump maintenance and empowerment of the maintenance team to be part of the solution.

McIntyre detailed some of the improvement. "We have documented an annual reduction in pump maintenance of \$200,000. Our MTBF has more than doubled since PRO Services arrived. Since 1999 our average pump life has been extended by 53%."

These improvements are expected to continue as new state-of-the-art predictive maintenance equipment goes on-line.

Thanks to the foresight of Cytec management and their manufacturing teams, the Fortier operation is working more efficiently, enhancing profitability and keeping production and jobs in Southeast Louisiana. ■

Send your comments or suggestions to:

John Beca - ITT Industrial Products Group, 240 Fall Street, Seneca Falls, NY 13148 or email: [john.becca@itt.com](mailto:john.becca@itt.com)

View the latest in pumping technology at: [www.gouldspumps.com](http://www.gouldspumps.com)